

# Montageanleitung

Assembly Instructions



# Inhaltsverzeichnis

## Table of contents

<b>1.</b>	<b>Allgemeine Hinweise</b> General notes	<b>3</b>
<b>2.</b>	<b>Montage der Beinraumblende</b> Assembly of leg room cover	<b>4</b>
<b>3.</b>	<b>Montage des Screens</b> Assembly of the screen	<b>4</b>
<b>4.</b>	<b>Montage des Bildschirmhalters</b> Mounting of the monitor arm	<b>5</b>
<b>5.</b>	<b>Montage des Druckertablars</b> Mounting of the printer tray	<b>6</b>
<b>6.</b>	<b>Montage des PC-Halters</b> Mounting of the PC holder	<b>7</b>
<b>7.</b>	<b>Verkettung</b> Concatenation	<b>8</b>
<b>8.</b>	<b>Beinraumblende (Standardtisch)</b> Leg room cover (standard table top)	<b>8</b>
<b>9.</b>	<b>Tischinstallation in und auf Schrank</b> Table installation in and on closet	<b>9</b>
<b>10.</b>	<b>Pflegehinweise</b> Care instructions	<b>10</b>

# 1. Allgemeine Hinweise

## General Notes

Vor Montagebeginn Transportverpackung entfernen und die Lieferung auf Vollständigkeit, Richtigkeit und Qualität überprüfen.

Separat verpackte Einsätze inklusive Elektrifizierungssets entnehmen.

In der Montageanleitung werden alle alternativen bzw. optionalen Ausstattungsvarianten dargestellt. Die für Sie gültigen Ausführungen entnehmen Sie bitte den entsprechenden Lieferunterlagen.

Before starting assembly, remove the transport packaging and check the delivery for completeness, correctness and quality.

Remove separately packed inserts including electrification sets.

All alternative or optional equipment variants are listed in the assembly instructions shown. Please refer to the relevant delivery documents for the versions that apply to you.

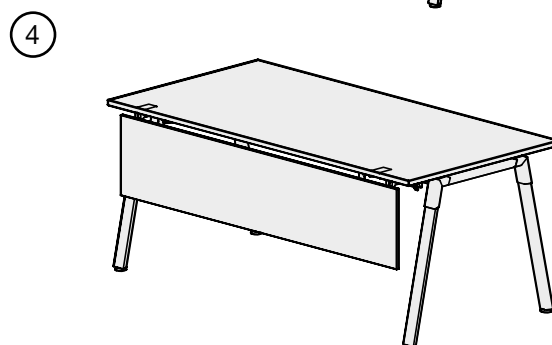
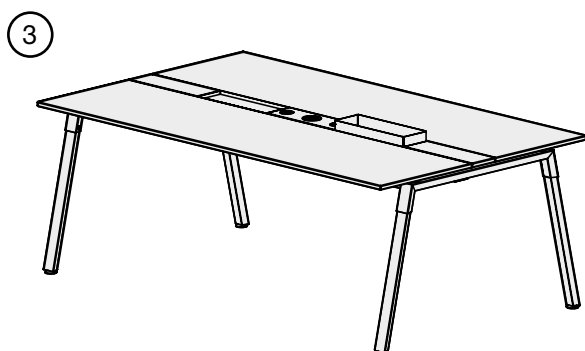
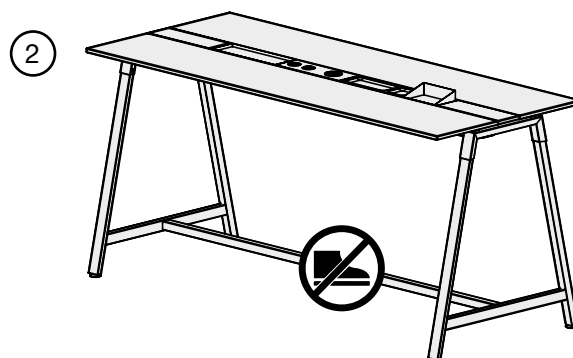
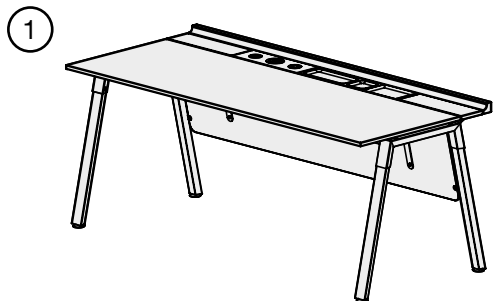

① Schreibtisch  
Desk

② Stehtisch  
High table

③ Besprechungstisch  
Meeting table

④ Variante mit Standardplatte  
variant with standard plate

## 2. Montage der Beinraumblende

Assembly of leg room cover

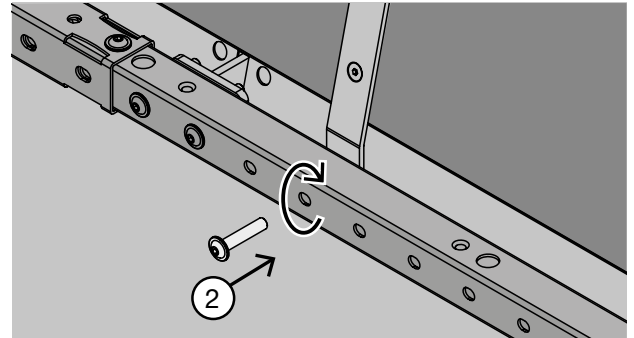
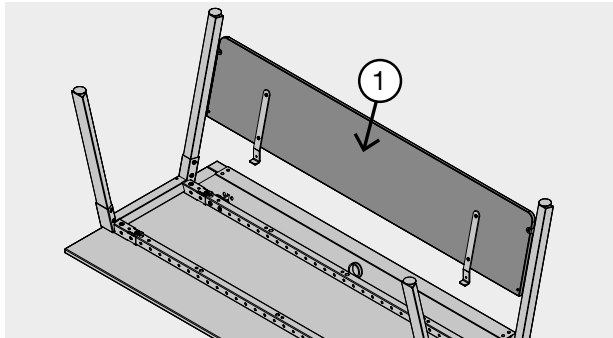
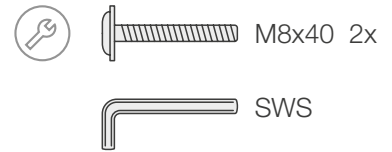
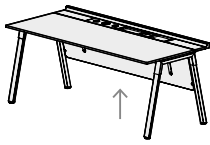

① Die Halter der Beinraumblende unter die Traverse schieben Slide the leg room cover holder under the crossbar

② Mit Montageschrauben befestigen Fasten with mounting screws

## 3. Montage des Screens

Assembly of the screen

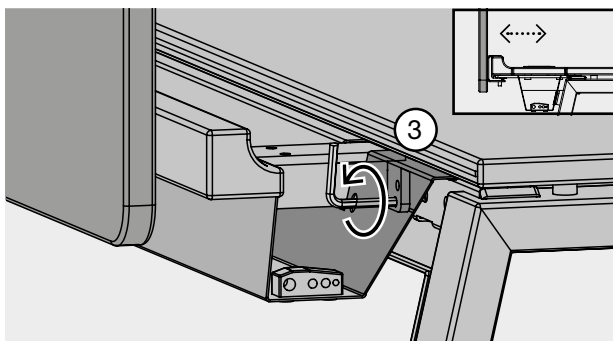
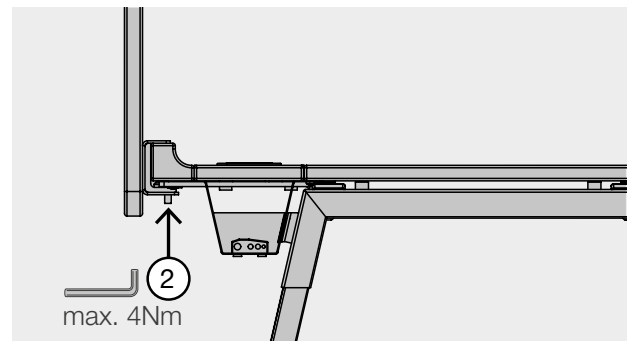
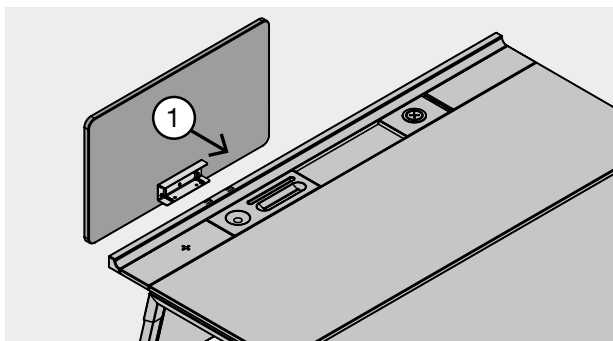

① Den Screen auf die Holzleiste schieben. Slide the screen onto the wooden strip.

② Beide Schrauben von unten anziehen, dabei das Anzugsdrehmoment beachten Tighten both screws from below, observing the tightening torque

③ Justierung des Screen. Adjustment of the screen.

## 4. Montage des Bildschirmhalters

### Mounting of the monitor arm

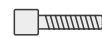

M8x100 1x



SW6

#### **A** Besprechungstisch & Stehtisch Conference table & high table

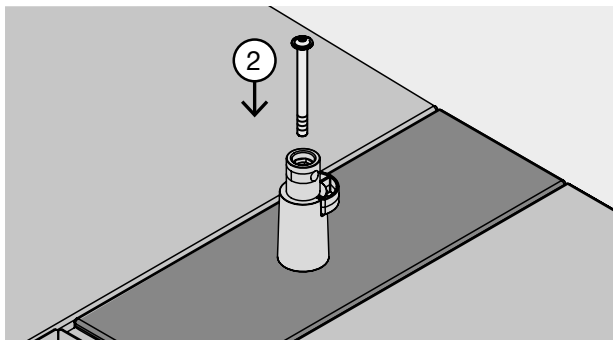
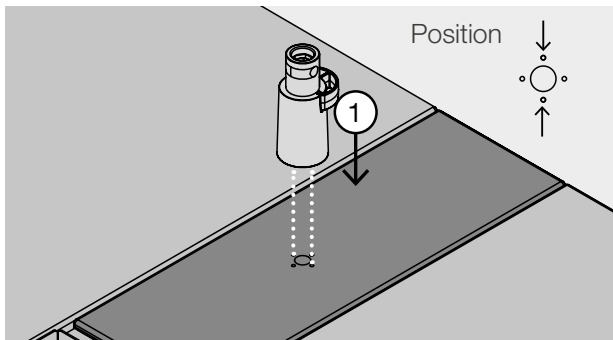
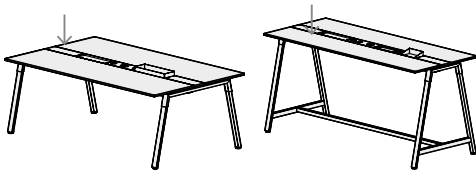

- ① Halter für den Monitortragarm positionieren und auf die richtige Montageposition achten. Position the holder for the monitor support arm and ensure that it is in the correct mounting position.
- ② Mit Montageschraube befestigen Fasten with mounting screw

#### **B** Schreibtisch Desk

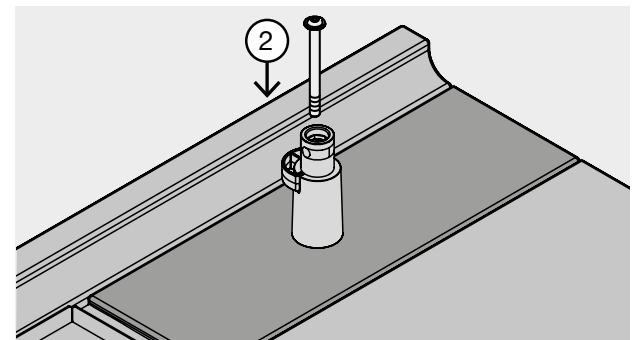
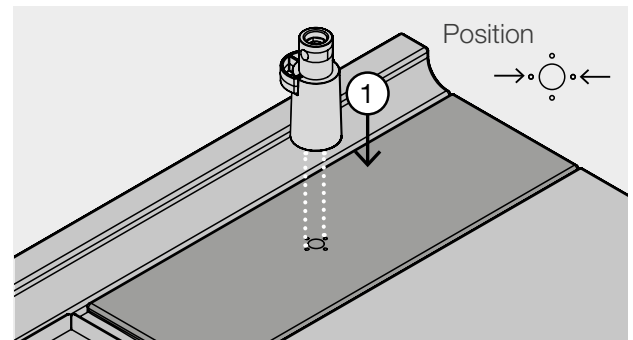
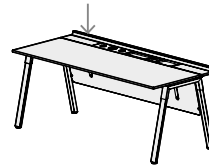





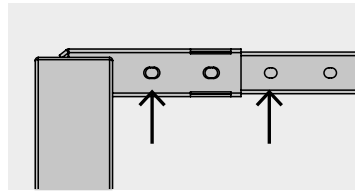
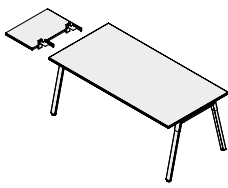

- ① Halter für den Monitortragarm positionieren und auf die richtige Montageposition achten. Position the holder for the monitor support arm and ensure that it is in the correct mounting position.
- ② Mit Montageschraube befestigen Fasten with mounting screw

## 5. Montage des Druckertablar

### Mounting of the printer tray



	<b>CS</b>		M8x60	4x		SW6
<b>US</b>			M8	4x		SW13
<b>CM</b>				2x		

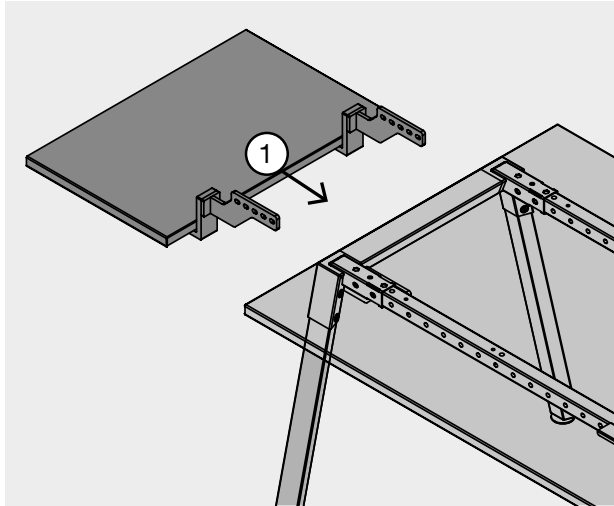

① Halter in Traverse einführen. Introduce the holder into the crossbeam.

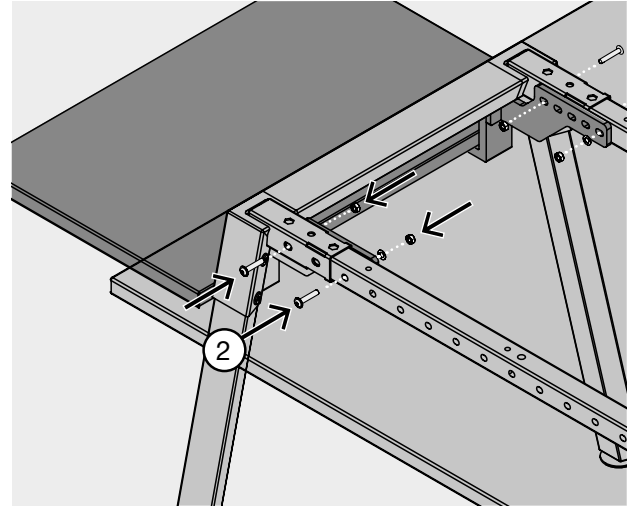







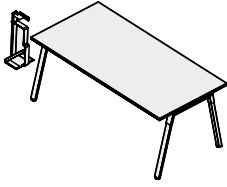

② Mit Montageschrauben befestigen. Fasten with mounting screws

## 6. Montage des PC-Halters

### Mounting of the PC holder



	<b>CS</b>		M8x60	2x		SW6
	<b>US</b>		M8	2x		SW13
	<b>CM</b>			1x		

#### A Vormontiert innen

#### Preassembled inside

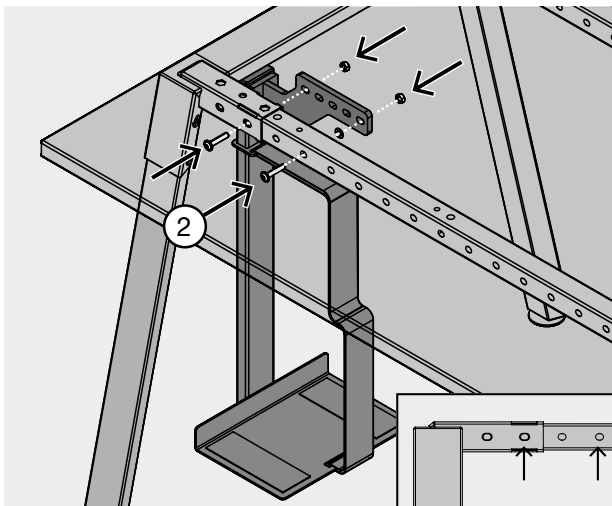
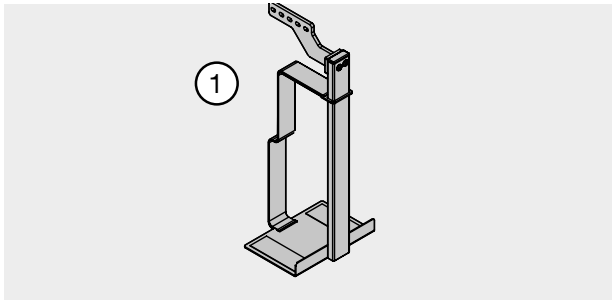

- ① Bei Innenmontage ist der PC Halter vormontiert  
The PC holder is pre-assembled for the installation on the inside
- ② Befestigung des PC Halters am Tisch nach Innen  
Attachment of the PC holder to the table inside

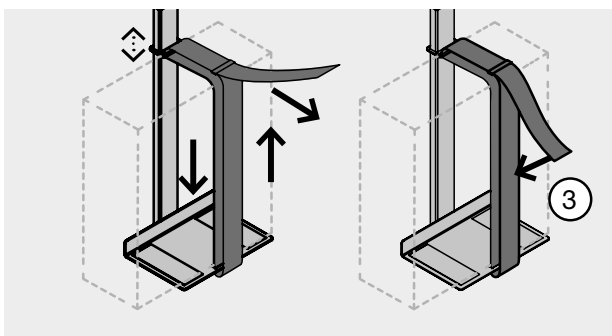

#### B Montage außen

#### Outside assembly

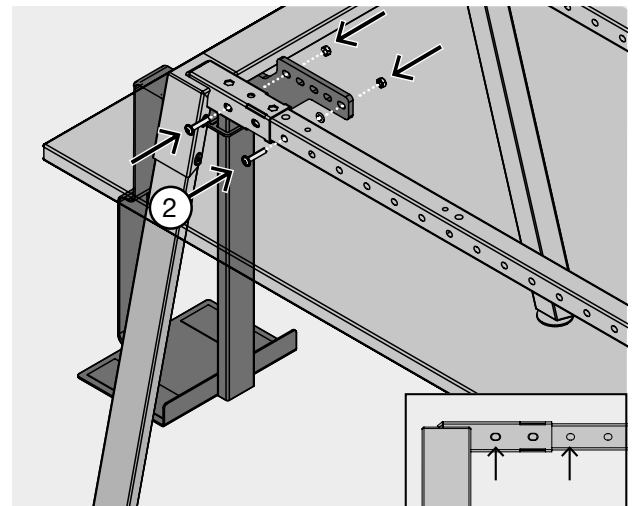
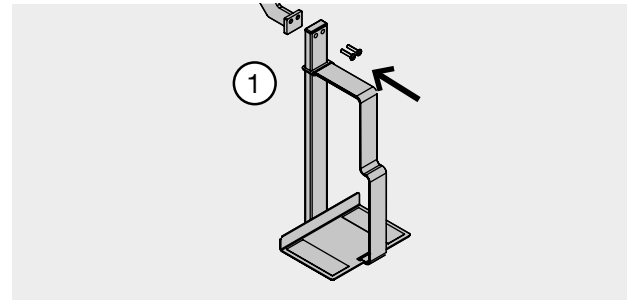

- ① Befestigung des PC Halters an Träger nach Außen  
Attachment of the PC holder to the carrier on the outside
- ② Befestigung des PC Halters am Tisch nach Außen  
Attachment of the PC holder to the table to the outside

- ③ PC mit Spanngurt befestigen  
Fasten the PC with a tension belt

## 7. Verkettung Concatenation

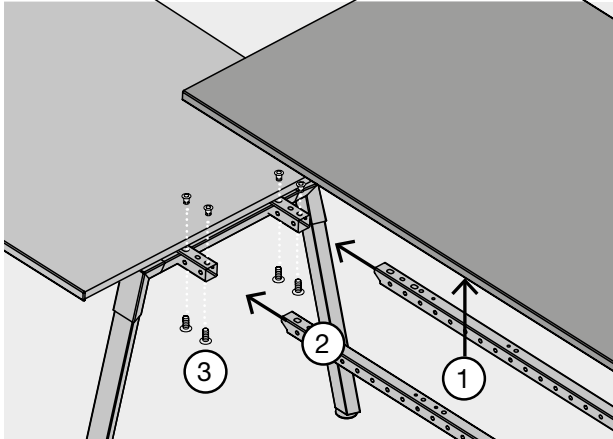
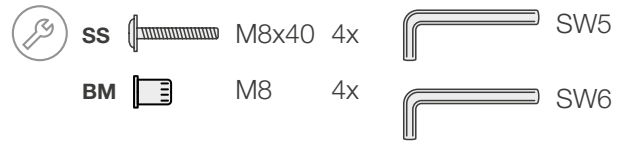
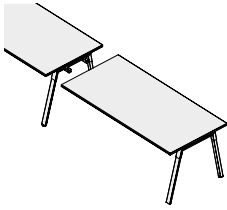

- ① Tischplatte demontieren  
Disassemble the table top
- ② Traversen in die Wange schieben  
Push the crossbars into the cheek

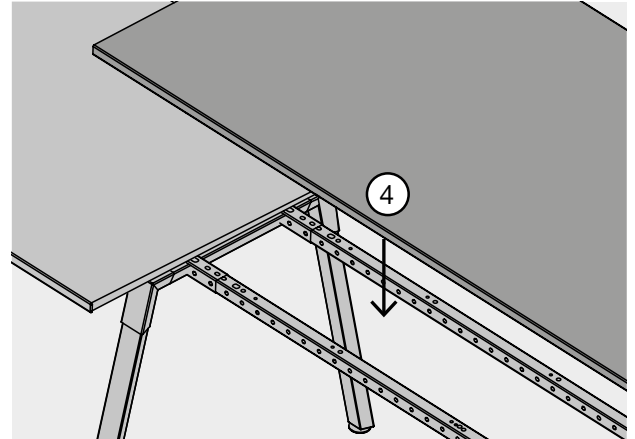

- ③ Mit Montageschrauben befestigen  
(Anzugsdrehmoment 10-16 Nm).  
Fasten with mounting screws  
(Tightening torque 10-16 Nm)
- ④ Tischplatte montieren  
Mount the table top

## 8. Beinraumblende (Standardtischplatte) Leg room cover (standard table top)

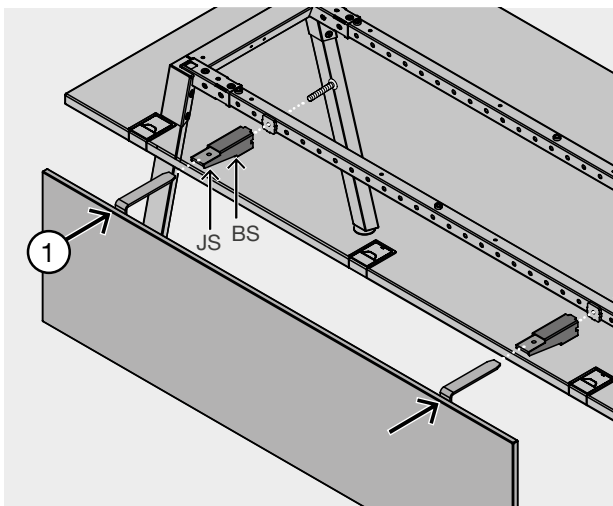
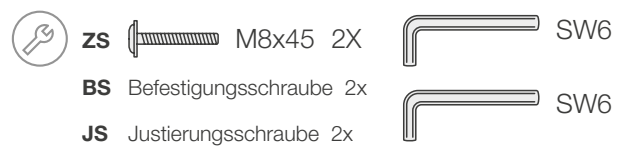
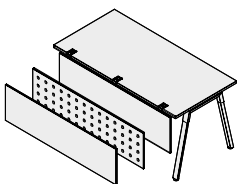

- ① Beinraumblende montieren. Die Schraube **BS** dient zur Befestigung, die Schraube **JS** zur Justierung der Abschirmung  
Mount the leg room cover. The BS screw is used for fastening, the JS screw for adjusting the shielding



## 9. Tischinstallation in und auf Schrank

Table installation in and on closet

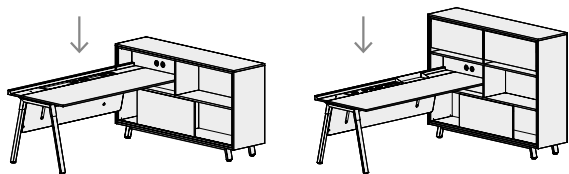

### A In Schrank In closet

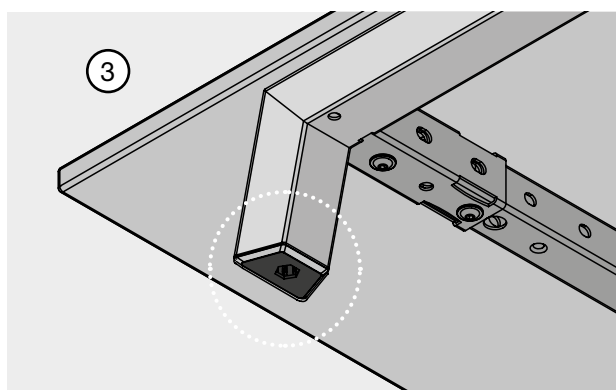
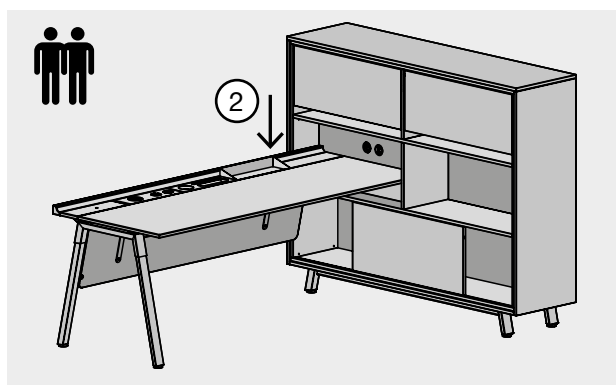
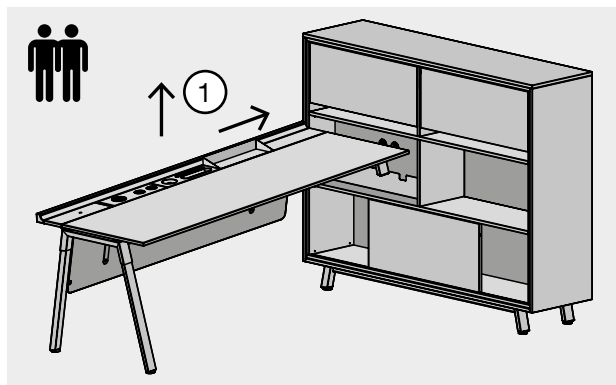

- ① Tisch anheben Lift the table
- ② Tisch in Einstellmodul platzieren und bis zur Rückwand in de Korpus schieben  
Place the table in setting module and push it up to the rear wall
- ③ Antirutschkappe slip resistant cap

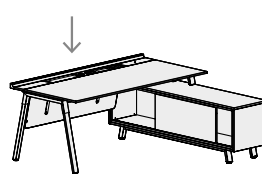

### B Auf Schrank On closet

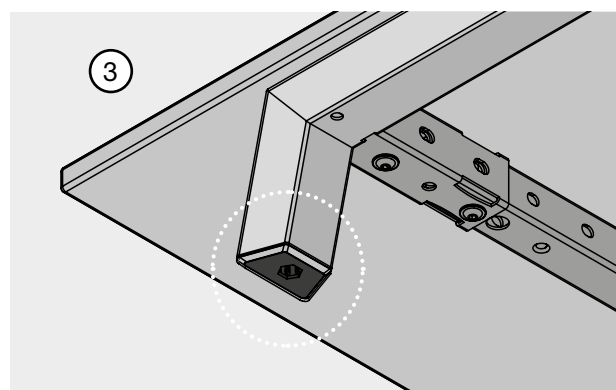
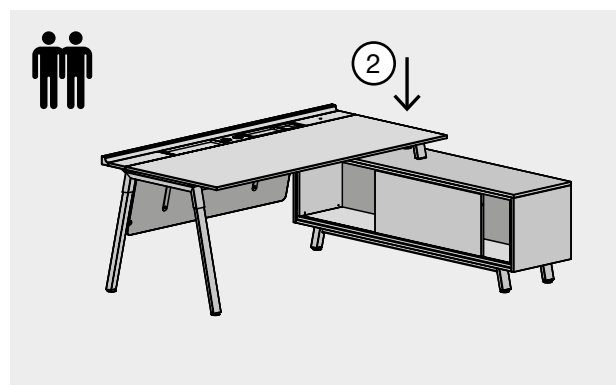
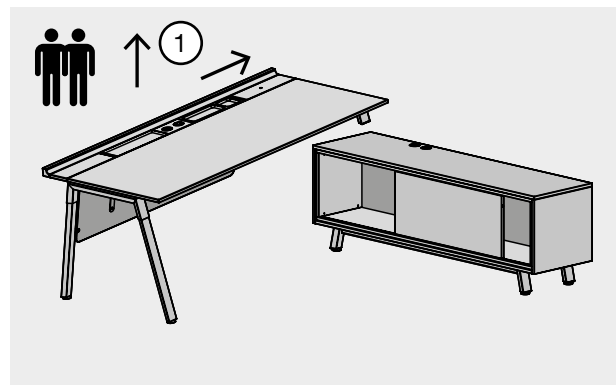

- ① Tisch anheben Lift the table
- ② Tisch auf Schrank platzieren (min. 100 mm Abstand zwischen Tischfüßen und Korpuskante)  
Place the table on the cabinet (min. 100 mm distance between table feet and body edge)
- ③ Antirutschkappe slip resistant cap

# 10. Pflegehinweise

## Care instructions

### Anwendung bei glatten Flächen

Reinigung mit weichen, sauberen, nicht flusenden Tüchern, Wasser und etwas handelsüblichem Allzweckreiniger oder Geschirrspülmittel. Oberflächen ohne starken Druck abwischen (kein Polieren, kein Scheuern!), dann mit trockenem Tuch nachwischen. Bei hartnäckigen Verschmutzungen Reinigungsmittel in höherer Konzentration anwenden, jedoch niemals unverdünnt! Danach unbedingt mit klarem Wasser nach- und trocken wischen. Offene porige Möbeloberflächen dürfen immer nur feucht, nicht nass behandelt werden.

Auf keinen Fall Scheuermittel oder aggressive Bad- und WC-Reiniger benutzen!

**⚠** Reinigungs- und Desinfektionsmittel dürfen weder einen zu hohen alkalischen noch sauren Wert haben (pH-Wert 6-8).

### Anwendung bei Flächen mit Einbauten

Reinigung von Bauteilen, bei denen die Beleuchtung in den Boden eingearbeitet ist, sowie in an Stellen, bei denen sich Steckdosen und USB-Anschlüsse befinden. Die Pflege an diesen Bereichen kann nur mit „nebelfeuchten Lappen“ erfolgen.

### Anwendung bei geölten Massivholzflächen

Für die tägliche Reinigung ausschließlich trockenes, maximal nebelfeuchtes Baumwolltuch verwenden und trocken nachwischen. Keine Mikrofasertücher verwenden. Verschmutzungen nur mit geeigneter Möbelseife reinigen. Keine fettlösenden Haushaltsreiniger verwenden. Reinigungsmittel vor Nutzung an nicht sichtbarer Stelle testen.

### Use on smooth surfaces

The surfaces of the furniture should only be cleaned with soft, clean and lint-free cloths and a small quantity of commercially available cleaning agents added to the water. Wipe surfaces slightly and without applying any pressure (do not polish or use abrasive agents). Re-wipe the surfaces with a dry cloth. In case of persistent soiling the cleaning agents can be used in a higher concentration, but never undiluted! Re-wipe the surfaces with clean water and dry them subsequently. Furniture surfaces with open pores must only be cleaned with a damp cloth and never be treated wet.

While abrasive cleaning agents must not be used at all, the use of any aggressive cleaning agents for toilets and bathing tubs is not recommended either.

**⚠** Detergents and disinfectants must not have too high an alkaline or acidic value (pH 6-8).

### Use on surfaces with built-in components

Cleaning of components in which the lighting is incorporated into the floor, as well as in places where there are sockets and USB connections. The maintenance of these areas can only be done with „slightly damp cloths“.

### Use on oiled solid wood surfaces

For daily cleaning, use only a dry cotton cloth that is if any slightly damp and wipe dry. Do not use microfiber cloths. Clean soiling only with suitable furniture soap. Do not use grease-dissolving household cleaners. Before using the cleaning supplies, test it in an invisible place.